



LED Surface Mount Light

SML-781



Product Description:

Rugged traditional aluminum die cast housing provides proven environmental protection for LED modules. Traditional fixture designs provide a familiar look and standard installation requirements. Retaining this look allows the ability to upgrade fixtures gradually, while retaining the same overall fixture appearance throughout a facility.

Performance Data:

Model NO.	System Watts	Lumens	LPW
SML-781	80W	8615 lm**	109 lm/w
Lumen and Efficacy are based on the highest wattage at 5000K			

Specification:

Model No.	SML-781		
System watts	43W	64W	80W
Lumen Output	3908 lm**	5699 lm**	8615 lm**
Color	3000K/4000K/4500K/5000K		
Input Voltage	120~277V		
CRI	80+		
Starting Temp	-40°C		
Equivalent	175W MH	400W MH	400W MH

Dimensions

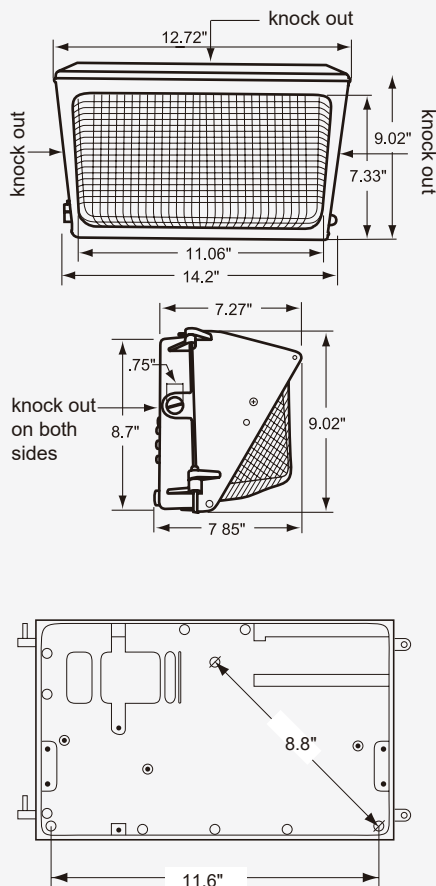

* Different LED Kelvin temperature available with 4-6 week lead time. Please call for a quote.

** DISCLAIMER: This test report was produced in accordance with IES LM-79 photometric testing protocol for luminaires, using a single representative test fixture. Actual production units may vary from the values reported here by up to ±10%.